

# LEVEL TRANSMITTER

DATA SHEET

FKE...5

The FCX-AIII level transmitter accurately measures liquid level and transmits a proportional 4 to 20mA signal. The transmitter utilizes a unique micromachined capacitance silicon sensor with state-of-the-art microprocessor technology to provide exceptional performance and functionality.

## FEATURES

- High accuracy**  
 0.2% accuracy for all calibrated spans is a standard feature for all models covering 0.32kPa {3.2mbar} range to 500kPa {5bar} high differential pressure range. 0.1% accuracy is available as option. Fuji's micro-capacitance silicon sensor assures this accuracy for all elevated or suppressed calibration ranges without additional adjustment.
- Minimum environmental influence**  
 The "Advanced Floating Cell" design which protects the pressure sensor against changes in temperature, static pressure, and overpressure substantially reduces total measurement error in actual field applications.
- Fuji/HART® bilingual communications protocol**  
 FCX-AIII series transmitter offers bilingual communications to speak both Fuji proprietary protocol and HART®. Any HART® compatible devices can communicate with FCX-AIII.
- Application flexibility**  
 Various options that render the FCX-AIII suitable for almost any process applications include:
  - Full range of hazardous area approvals
  - Built-in RFI filter and lightning arrester
  - 5-digit LCD meter with engineering unit
  - Stainless steel electronics housing
  - Wide selection of materials
  - High temperature, high vacuum service.
- Programmable output Linearization Function**  
 Output signal can be freely programmable. (Up to 14 compensated points at approximation.)
- Burnout current flexibility (Under Scale: 3.2 to 4.0mA, Over Scale: 20.0 to 22.5mA)**  
 Burnout signal level is adjustable using Model FXW Hand Held Communicator (HHC) to comply with NAMUR NE43.
- Dry calibration without reference pressure**  
 Thanks to the best combination of unique construction of mechanical parts (Sensor unit) and high performance electronics circuit (Electronics unit), reliability of dry calibration without reference pressure is at equal level as wet calibration.



## SPECIFICATIONS

### Functional specifications

**Service:** Liquid, gas, or vapor  
**Static pressure, span, and range limit:**

Type	Static pressure	Span limit [kPa] {m bar}		Range limit [kPa] {m bar}
		Min.	Max.	
FKE□□3	Up to flange rating	0.32 (3.2)	32	+/- 32
FKE□□5		{3.2(3.2)}	{320}	{+/- 320}
		1.3 (13)	130	+/- 130
FKE□□6		{13(130)}	{1300}	{+/- 1300}
	5 (50)	500	+/- 500	
	{50(500)}	{5000}	{+/- 5000}	

Remark: To minimize environmental influence, span should be greater than 1/40 of the max. span in most applications.

Note: Minimum span for flange whose diameter is 50A/2B/2 inch or smaller are shown in parentheses.

- Lower limit of static pressure (vacuum limit) ;  
 Silicone fill sensor: See Fig.1  
 Fluorinated fill sensor: 66kPa abs (500mmHg abs) at temperature below 60 °C.
- The maximum span of each sensor can be converted to different units using factors as below.  
 1MPa=10<sup>3</sup>kPa=10bar=10.19716kgf/cm<sup>2</sup>=145.0377psi  
 1kPa=10mbar=101.9716mmH<sub>2</sub>O=4.01463inH<sub>2</sub>O

**Overrange limit:** To maximum static pressure limit  
**Output signal:** 4 to 20mA DC with digital signal superimposed on the 4 to 20mA signal  
**Power supply:** Transmitter operates on 10.5V to 45V DC at transmitter terminals. 10.5V to 32V DC for the units with optional arrester.

**Load limitations:** see figure below

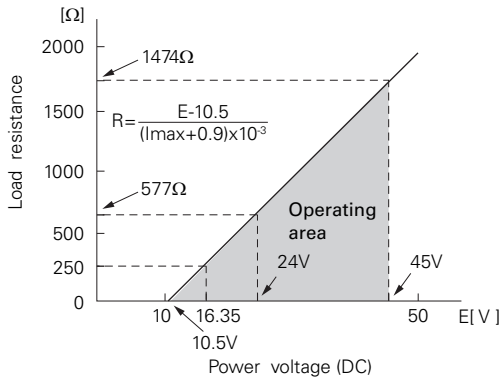

Note: For communication with HHC<sup>(1)</sup> (Model: FXW), min. of 250Ω required.

**Hazardous locations:** See TABLE 2

**Zero/span adjustment:**

Zero and span are adjustable from the HHC<sup>(1)</sup>. Zero and span are also adjustable externally from the adjustment screw.

**Damping:** Adjustable from HHC or local configurator unit with LCD display.

The time constant is adjustable between 0.06 to 32 seconds.

**Zero elevation/suppression:**

-100% to + 100% of URL

**Normal/reverse action:**

Selectable from HHC<sup>(1)</sup>

**Indication:** Analog indicator or 5-digit LCD meter, as specified.

**Burnout direction:** Selectable from HHC<sup>(1)</sup>

If self-diagnostic detect transmitter failure, the analog signal will be driven to either "Output Hold", "Output Overscale" or "Output Underscale" modes.

"Output Hold": Output signal is hold as the value just before failure happens.

"Output Overscale":

Adjustable within the range 20.0mA to 21.6mA from HHC<sup>(1)</sup>

Note: When the ambient temperature is -30°C or lower: 20.0mA to 20.8mA.

"Output Underscale":

Adjustable within the range 3.2mA to 4.0mA from HHC<sup>(1)</sup>

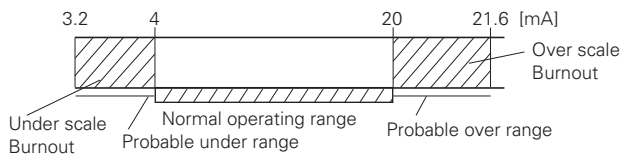

Output Limits conforming the NAMUR NE43 by order.

**Loop-check output:**

Transmitter can be configured to provide constant signal 3.2mA through 21.6mA by HHC<sup>(1)</sup>.

**Temperature limit:**

Ambient: -40 to + 85°C

(-20 to + 80°C for LCD indicator)

(-40 to + 60°C for arrester option)

(-10 to + 60°C for fluorinated oil fill transmitter)

For explosionproof units (flameproof or intrinsic safety), ambient temperature must be within the limits specified in each standard.

**Process:**

	Code in the 13th digit of "Code symbols"	Process temperature	Lower limit of static press
Fluorinated oil	W, A and D	-20 to 120°C	Atmospheric pressure
Silicone oil	U	-15 to 250°C	
	X	20 to 300°C	
	Y and G	-40 to 20°C	2.7kPa abs {20.3mmHg abs}

Low pressure side contact liquid temperature on transmitter of Code H, J is 120°C or lower.

Storage: -40 to + 90°C

**Humidity limit:** 0 to 100% RH

**Communication:** With HHC<sup>(1)</sup> (Model FXW, consult Data Sheet No. EDS8-47), following items can be remotely displayed or configured.

Note: HHC's version must be higher than 7.0 (or FXW□□□□1-□4), for FCX -AIII.

**Local configurator with LCD display (option):**

Local configurator with 3 push button and LCD display can support following items.

Items	By communication with FXW		By local configurator (with 3 push button)	
	Display	Set	Display	Set
Tag No.	✓	✓	✓	✓
Model No.	✓	✓	✓	✓
Serial No. & Software Version	✓	—	✓	—
Engineering unit	✓	✓	✓	✓
Range limit	✓	—	✓	—
Measuring range	✓	✓	✓	✓
Damping	✓	✓	✓	✓
Output mode	✓	—	✓	—
Burnout direction	✓	✓	✓	✓
Calibration	✓	✓	✓	✓
Output adjust	—	✓	—	✓
Data	✓	—	✓	—
Self diagnoses	✓	—	✓	—
Printer (In case of FXW with printer option)	✓	—	—	—
External switch lock	✓	✓	✓	✓
Transmitter display	✓	✓	✓	✓
Linearize	✓	✓	—	—
Rerange	✓	✓	✓	✓
Saturate current	✓	✓	✓	✓
Write protect	✓	✓	✓	✓
History				
— Calibration history	✓	✓	✓	✓
— Ambient temperature history	✓	—	✓	—

**Programmable output linearization function:**

Output signal can be characterized with "14 points linear approximation function" from HHC<sup>(1)</sup>.

(Note) (1) HHC: Hand Held Communicator

## Performance specifications

Reference conditions, silicone oil fill, 316L SS isolating diaphragms, 4-20 mA analog output in linear mode.

**Accuracy rating:** (including linearity, hysteresis, and repeatability)

(Standard)

For spans greater than 1/10 of URL:  $\pm 0.2\%$  of span

For spans below 1/10 of URL:

$$\pm \left( 0.1 + 0.1 \frac{0.1 \times \text{URL}}{\text{Span}} \right) \% \text{ of span}$$

(Option) (Code: 21th digit H, K)

For span greater than 1/10 of URL: 0.1% of span

For span below 1/10 of URL:

$$\pm \left( 0.05 + 0.05 \frac{0.1 \times \text{URL}}{\text{Span}} \right) \% \text{ of span}$$

**Stability:**  $\pm 0.2\%$  of upper range limit (URL) for 10 years.

**Temperature effect:**

Effects per 28°C change between the limits of -40°C and +85°C

(Standard) Zero shift:  $\pm \left( 0.35 \frac{\text{URL}}{X} \right) \%$

Total effect:  $\pm \left( 0.5 \frac{\text{URL}}{X} \right) \%$

(Option) (Code: 21th digit J, K)

Zero shift:  $\pm 0.3\%$  ( $X > 1/4 \text{URL}$ )

$$\pm \left( 0.1 + 0.2 \frac{0.25 \times \text{URL}}{X} \right) \% (X < 1/4 \text{URL})$$

Total effect:  $\pm 0.4\%$  ( $X > 1/4 \text{URL}$ )

$$\pm \left( 0.2 + 0.2 \frac{0.25 \times \text{URL}}{X} \right) \% (X < 1/4 \text{URL})$$

**Static pressure effect:**

Zero shift:  $\pm 0.2\%$  of URL / 1MPa

Span shift:  $-0.2\%$  of calibrated span / 1MPa

**Overrange effect:** Zero shift;  $\pm 0.1\%$  of URL for flange rating pressure

**Supply voltage effect:**

Less than 0.005% of calibrated span per 1V

**Update rate:** 60 msec

**Step response:** (without electrical damping)

Range code	Time constant (at 23°C)	Dead time
"3"	0.55 s	0.12 s
"5" and "6"	0.3 s	

**Mounting position effect:**

Zero shift, less than 0.3kPa {3m bar} for a 10° tilt in any plane. (No extension)

No effect on span.

This error can be corrected by adjusting zero.

**Dielectric strength:**

500V AC, 50/60Hz 1 min., between circuit and earth.

**Insulation resistance:**

More than 100MΩ at 500V DC.

**Internal resistance for external field indicator:**

12Ω or less

## Physical specifications

**Electrical connections:**

G<sup>1</sup>/<sub>2</sub>, 1/2-14 NPT, Pg13.5, or M20 × 1.5 conduit, as specified.

**Process connections:**

LP side: 1/4-18 NPT or Rc<sup>1</sup>/<sub>4</sub>.

HP side: ANSI, DIN, or JIS raised face flange. See OUTLINE DIAGRAM for detailed dimensions.

Refer to "Code symbols"

**Process-wetted parts material:**

Material (7th code)	HP side (mounting flange side)		LP side	
	Diaphragm	Flange face	Diaphragm	Wetted sensor body
V	316L stainless steel	316L stainless steel	316L stainless steel	316L stainless steel
B	316L stainless steel + Au coating	316L stainless steel	316L stainless steel	316L stainless steel
W	Hastelloy-C	316L stainless steel	316L stainless steel	316L stainless steel
C	Hastelloy-C	Hastelloy-C	316L stainless steel	316L stainless steel
D	Monel	Monel	316L stainless steel	316L stainless steel
E	Tantalum	Tantalum	316L stainless steel	316L stainless steel
H	Hastelloy-C	Hastelloy-C	Hastelloy-C	Hastelloy-C
M	Monel	Monel	Monel	Monel
T	Tantalum	Tantalum	Tantalum	Tantalum
P	Titanium	Titanium	316L stainless steel	316L stainless steel
R	Zirconium	Zirconium	316L stainless steel	316L stainless steel

Process cover: 316L stainless steel

Remark: Sensor O-rings: Viton O-ring and teflon gasket selectable.

**Non-wetted parts material:**

Electronics housing:

Low copper die-cast aluminum alloy finished with polyester coating (standard), or 316L stainless steel, as specified.

Bolts and nuts:

Carbon steel (standard) or 304 stainless steel

Fill fluid:

Silicone oil (standard) or fluorinated oil

Mounting flange:

316L stainless steel

**Environmental protection:**

IEC IP67 and NEMA 6 / 6P

**Flange mounting:** See drawings

**Mass {weight}:** Transmitter approximately 10.2 to 19.2kg without options.

Add; 0.5kg for mounting bracket

4.5kg for stainless steel housing option

1.0kg per 50mm extension of diaphragm

**Optional features**

- Indicator:** A plug-in analog indicator (2.5% accuracy).  
An optional 5-digit LCD meter with engineering unit is also available.
- Local configurator with LCD display:** An optional 5 digits LCD meter with 3 push buttons can support items as using communication with FXW.
- Arrester:** A built-in arrester protects the electronics from lightning surges.  
Lightning surge immunity: 4kV (1.2 × 50µs)
- Oxygen service:** Special cleaning procedures are followed throughout the process to maintain all process wetted parts oil-free.  
The fill fluid is fluorinated oil.
- Chlorine service:** Oil-free procedures as above. Includes fluorinated oil for fill.
- Degreasing:** Process-wetted parts are cleaned, but the fill fluid is standard silicone oil. Not for use on oxygen or chlorine measurement.
- Vacuum service:** Special silicone oil and filling procedure are applied. See Fig.1 and Fig.2
- Optional tag plate:** An extra stainless steel tag with customer tag data is wired to the transmitter.

**EU Directive Compliance**

- EMC (2014/30/EU)**  
EN 61326-1 (Table 2)  
EN 55011 (Group 1 Class A)  
EN 61326-2-3
- ATEX (2014/34/EU)**  
EN 60079-0  
EN 60079-1  
EN 60079-11  
EN 60079-15  
EN 60079-26  
EN 60079-31
- PED (2014/68/EU)**  
Article 4.3
- RoHS (2011/65/EU)**  
EN 50581

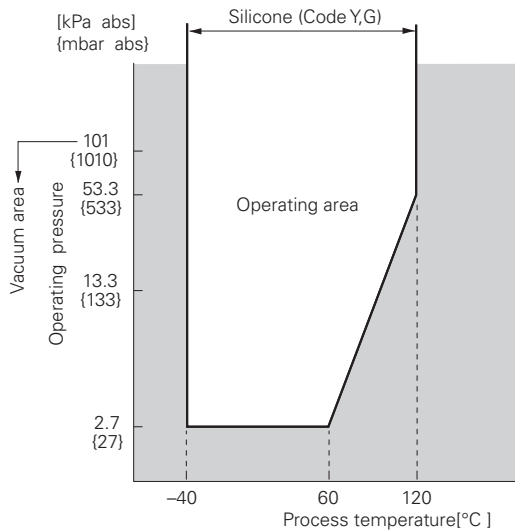

Fig. 1 Relation between process temperature and operating pressure

## ACCESSORIES

**Oval flanges:** (Model FFP, refer to Data Sheet No. EDS6-128)  
Converts process connection to 1/2-14 NPT or to Rc1/2; in carbon steel or in 316 stainless steel.

**Hand held communicator:**  
(Model FXW, refer to Data Sheet No. EDS 8-47)

## ORDERING INFORMATION

When ordering this instrument, specify:

1. CODE SYMBOLS
2. Measuring range
3. Output orientation (burnout direction) when abnormality is occurred in the transmitter.  
Hold / Overscale / Underscale.  
Unless otherwise specified, output hold function is supplied.
4. Indication method (indicated value and unit) in case of the actual scale (code D, H, P, S, 2, 5 on 9th digit).
5. TAG No. (up to 14 alphanumeric characters), if required.

# CODE SYMBOLS

Digit	Description	Note	1	2	3	4	5	6	7	8	9	10	11	12	13	14	15	Digit No. of code
4	<Low pressure Connections>	<AMP case>	F	K	E													
	<Process cover>	<Conduit connection>																
	<Process connection>	<Oval flange screw>	<Case shape>															
	Rc1/4	7/16-20UNF	G1/2	L shape														
	1/4-18NPT	7/16-20UNF	1/2-14NPT	L shape														
	1/4-18NPT	M10	Pg 13.5	L shape														
	1/4-18NPT	M10	M20	L shape														
	1/4-18NPT	7/16-20UNF	Pg 13.5	L shape														
	Rc1/4	7/16-20UNF	G1/2	T shape														
	1/4-18NPT	7/16-20UNF	1/2-14NPT	T shape														
1/4-18NPT	M10	Pg 13.5	T shape															
1/4-18NPT	M10	M20	T shape															
1/4-18NPT	7/16-20UNF	Pg 13.5	T shape															
5	<Flange size and rating>	<Flange material>																
	JIS 10K 40A	316L SS																
	JIS 20K 40A	316L SS																
	JIS 30K 40A	316L SS																
	JIS 10K 50A	316L SS																
	JIS 20K 50A	316L SS																
	JIS 30K 50A	316L SS																
	JIS 10K 80A	316L SS																
	JIS 20K 80A	316L SS																
	JIS 30K 80A	316L SS																
	JIS 10K 100A	316L SS																
	JIS 20K 100A	316L SS																
	JIS 30K 100A	316L SS																
	ANSI/JPI 150LB 1.5"	316L SS																
	ANSI/JPI 300LB 1.5"	316L SS																
	ANSI/JPI 150LB 2"	316L SS																
	ANSI/JPI 300LB 2"	316L SS																
	ANSI/JP1 150LB 3B	316L SS																
	ANSI/JP1 300LB 3B	316L SS																
	ANSI/JP1 150LB 4B	316L SS																
ANSI/JP1 300LB 4B	316L SS																	
DIN PN40 DN80	316L SS																	
DIN PN16 DN100	316L SS																	
6	<Span limit (*1) [kPa] {m bar}>	Note 1																
	[0.32 ..... 32] (For flange size 50A/2B or smaller: [3.2 ..... 32])																	
	{3.2 ..... 320} (For flange size 50A/2B or smaller: {32 ..... 320})																	
	[1.3 ..... 130] (For flange size 50A/2B or smaller: [13 ..... 130])																	
	{13 ..... 1300} (For flange size 50A/2B or smaller: {130 ..... 1300})																	
[5 ..... 500] (For flange size 50A/2B or smaller: [50 ..... 500]) (*2)	Note 2																	
{50 ..... 5000} (For flange size 50A/2B or smaller: {500 ..... 5000}) (*2)																		
7	<Material>																	
	HP side	LP side																
	Diaphragm	Flange face	Diaphragm	Wetted cell body														
	316L SS	316L SS	316L SS	316L SS														
	316L SS + Au coating	316L SS	316L SS	316L SS														
	Hastelloy-C	316L SS	316L SS	316L SS														
	Hastelloy-C	Hastelloy-C	316L SS	316L SS														
	Monel	Monel	316L SS	316L SS														
	Tatalum	Tatalum	316L SS	316L SS														
	Hastelloy-C	Hastelloy-C	Hastelloy-C	Hastelloy-C														
	Monel	Monel	Monel	Monel														
	Tatalum	Tatalum	Tatalum	Tatalum														
Titanium	Titanium	316L SS	316L SS	Note 3														
Zirconium	Zirconium	316L SS	316L SS	Note 3														
9	<Indicator>	<Scale>	<Arrester>															
	None	---	None															
	Analog	0 to 100% linear scale	None															
	Analog	Custom scale	None															
	None	---	Yes															
	Analog	0 to 100% linear scale	Yes															
	Analog	Custom scale	Yes															
	Digital	0 to 100% linear scale	None															
	Digital	Custom scale	None															
	Digital	0 to 100% linear scale	Yes															
	Digital	Custom scale	Yes															
	Digital (Local configurator unit with LCD)	0 to 100% linear scale	None															
	Digital (Local configurator unit with LCD)	Custom scale	None															
	Digital (Local configurator unit with LCD)	0 to 100% linear scale	Yes															
	Digital (Local configurator unit with LCD)	Custom scale	Yes															

Note 1: (\*1) 100: 1 turn down is possible, but should be used as a span greater than 1/40 of the maximum span for better performance.

Note 2: (\*2) Not available for 7th digit code "R".

Note 3: (\*3) 5th digit code "0, 2, 4, 6, 8, T" are available.

Digit	Description	Note	1	2	3	4	5	6	7	8	9	10	11	12	13	14	15	← Digit No. of code
10	<Approvals for hazardous location> None (for ordinary location) TIIS Flameproof (Cabel grand seal) (*5) TIIS Intrinsic safety FM Flameproof (or explosionproof) (*6) FM Intrinsic safety FM Combined of flameproof and intrinsic safety (*6) ATEX Flameproof (*7) ATEX Intrinsic safety ATEX Type n ATEX Combined of flameproof and intrinsic safety (*7) IECEX scheme, Flameproof (*7) IECEX scheme, Intrinsic safety CSA Flameproof (or explosionproof) (*6) CSA Intrinsic safety and nonincensive	Note 4 Note 5 Note 5 Note 6 Note 6 Note 6 Note 6 Note 5	F	K	E					5								
11	<Diaphragm extension [mm]> <Extension [mm]> 0 mm 50 mm 100 mm 150 mm 200 mm	<Applicable material code (7th code)> Any "V" only "V" only "V" only "V" only																
12	<Option> <Extra SS tag plate> None Yes None Yes	<SS electric housing> None None Yes Yes																
13	<Treatment> Standard Standard Degreasing Oxygen service Chlorine service High temp. High temp.	<Fill fluid> Silicone oil Fluorinated oil Silicone oil Fluorinated oil (7th code "V" only) Fluorinated oil (7th code "H", "T", "C", and "E") Silicone oil High temp. 250°C Silicone oil High temp. 300°C																
14	<O-ring/Gasket> Standard Standard A-type long vent A-type long vent	<Vent/drain plug type> Teflon (FEF design) Teflon (FEF design) Teflon (FEF design) Teflon (FEF design)	<Bolt for LP side> (*10) Carbone steel (Carbon steel hexagon socket head cap bolt / nut) 316 SS bolt / 316 SS nut Carbone steel (Carbon steel hexagon socket head cap bolt / nut) 316 SS bolt / 316 SS nut															
15	<Other options> None Opposite Vent/drain plug position None Opposite Vent/drain plug position High accuracy Low temperature effect High accuracy + Low temperature effect High accuracy Low temperature effect High accuracy + Low temperature effect	<Instruction manual> Yes Yes None None Yes Yes Yes None None None																

- Note 4 : (\*4) Available for 4th digit code "S".  
Note 5 : (\*5) Available for 4th digit code "6", "T".  
Note 6 : (\*6) Available for 4th digit code "6", "8", "T", "W".  
Note 7 : (\*7) Customer tag number can be engraved on standard stainless steel name plate. If extra tag plate is required, select "Yes".  
Note 8 : (\*8) Not available for 4th digit code "5" to "9", and 10th digit code "C".  
Note 9 : (\*9) For use in tropics, select stainless bolts and nuts.



# OUTLINE DIAGRAM (Unit:mm)

<AMP. case: L type>

4th digit of the code symbols	conduit conn.			Press. Conn. S	Oval flange screw
	J	K	M		
S	G1/2	18	2	Rc 1/4	7/16-20UNF
T	1/2-14NPT	16	4	1/4-18NPT	7/16-20UNF
V	Pg13.5	10.5	4.5	1/4-18NPT	M10
W	M20x1.5	16	4	1/4-18NPT	M10
X	Pg13.5	10.5	4.5	1/4-18NPT	7/16-20UNF

TABLE 1

11th digit of the code symbols	L±1.5	MASS APPROX. (kg)	L1	L2	L3	NOTE3)		
						L4	L5	L6
Y	0	10.2 ~ 13.7	285	128	255	290	130	257
A	50	10.7 ~ 17.7						
B	100	11.2 ~ 18.2						
C	150	11.7 ~ 18.7						
D	200	12.2 ~ 19.2						

5th digit of the code symbols	φD	φE	φF	φG	φH±1	t	N-φh	FLANGE
A	140	105	81	53	—	16	4-19	JIS 10K 40A
B	140	105	81	53	—	18	4-19	JIS 20K 40A
C	160	120	90	53	—	22	4-23	JIS 30K 40A
D	155	120	96	70	48	16	4-19	JIS 10K 50A
E	155	120	96	70	48	18	8-19	JIS 20K 50A
F	165	130	105	70	48	22	8-19	JIS 30K 50A
O	185	150	126	100	73	18	8-19	JIS 10K 80A
T	200	160	132	100	73	22	8-23	JIS 20K 80A
2	210	170	140	100	73	28	8-23	JIS 30K 80A
1	210	175	151	103	96	18	8-19	JIS 10K 100A
U	225	185	160	103	96	24	8-23	JIS 20K 100A
3	240	195	160	103	96	32	8-25	JIS 30K 100A
G	127	98.4	73	53	48	17.5	4-16	ANSI/JPI 150LB 1.5B
H	156	114.3	73	53	48	20.6	4-23	ANSI/JPI 300LB 1.5B
J	150	120.6	92	70	48	20	4-20	ANSI/JPI 150LB 2B
K	165	127	92	70	48	22.5	8-20	ANSI/JPI 300LB 2B
4	190	152.5	127	100	73	24	4-20	ANSI/JPI 150LB 3B
6	210	168	127	100	73	29	8-23	ANSI/JPI 300LB 3B
5	230	190.5	158	103	96	24	8-20	ANSI/JPI 150LB 4B
7	255	200	158	103	96	32	8-23	ANSI/JPI 300LB 4B

OPTION PARTS FOR FLAMEPROOF OF THIS (JAPAN)

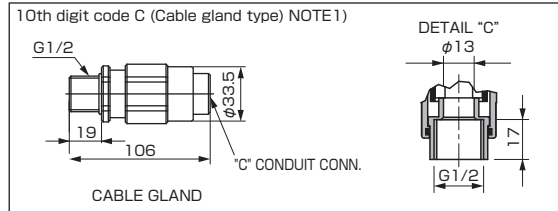

NOTE1) IN CASE OF 10TH DIGIT CODE "C", φ11 CABLE IS SUITBLE.  
 NOTE2) THE PRESSURE CONNECTOR IS LOCATED ON THE DOWN SIDE SURFACE OF THE DETECTOR. WHEN THE VENT/RAINPLUG IS ATTACHED ON THE UPPER SIDE OF THE DETECTOR (WHEN THE 15TH DIGIT OF THE CODE SYMBOLS : C,E,D,P,Q,R).  
 NOTE3) WHEN THE 7TH DIGIT OF THE CODE SYMBOLS "H,M,T"

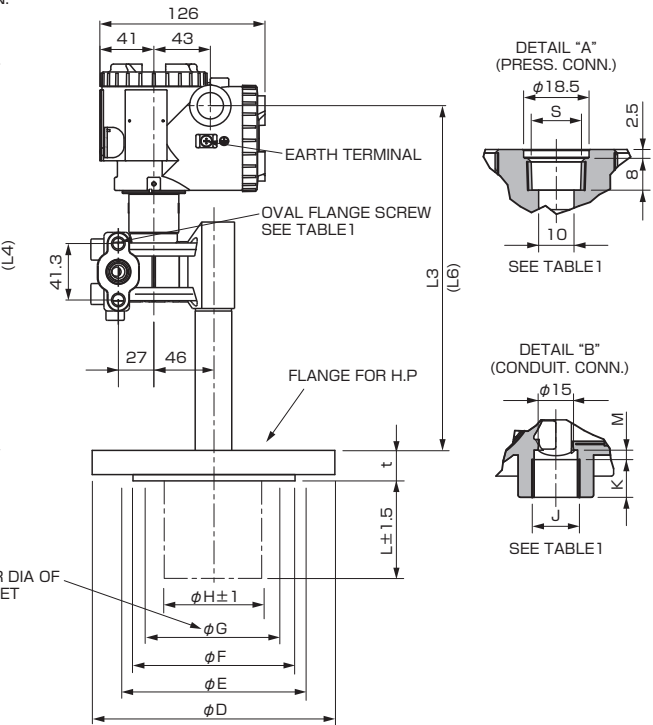
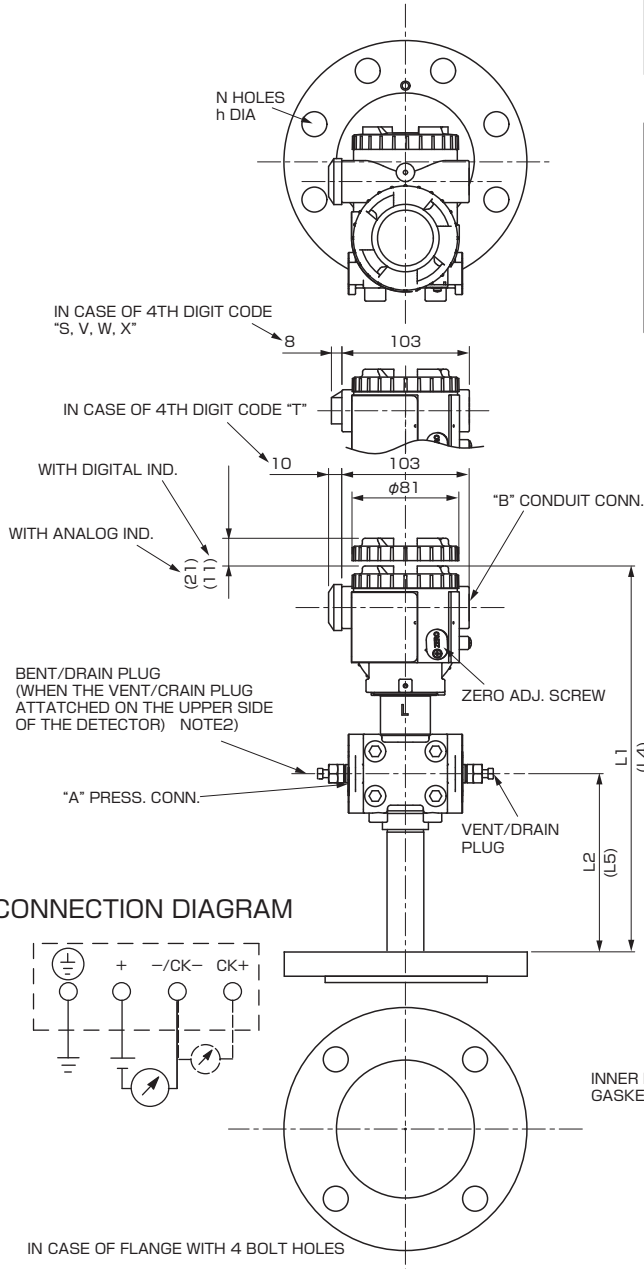



### <AMP. case: T type>

DETAIL "A"(PRESS. CONN.)

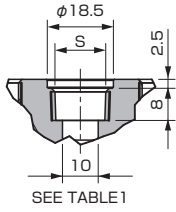

DETAIL "B"(CONDUIT. CONN.)

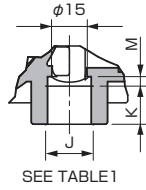

4th digit of the code symbols	conduit conn.			Press. Conn.	Oval flange screw
	J	K	M	S	
5	G1/2	18	2	Rc 1/4	7/16-20UNF
6	1/2-14NPT	16	4	1/4-18NPT	7/16-20UNF
7	Pg13.5	10.5	4.5	1/4-18NPT	M10
8	M20x1.5	16	4	1/4-18NPT	M10
9	Pg13.5	10.5	4.5	1/4-18NPT	7/16-20UNF

TABLE 1

5th digit of the code symbols	φD	φE	φF	φG	φH±1	t	N-φh	FLANGE
A	140	105	81	53	48	16	4-19	JIS 10K 40A
B	140	105	81	53	48	18	4-19	JIS 20K 40A
C	160	120	90	53	48	22	4-23	JIS 30K 40A
D	155	120	96	70	48	16	4-19	JIS 10K 50A
E	155	120	96	70	48	18	8-19	JIS 20K 50A
F	165	130	105	70	48	22	8-19	JIS 30K 50A
O	185	150	126	100	73	18	8-19	JIS 10K 80A
T	200	160	132	100	73	22	8-23	JIS 20K 80A
2	210	170	140	100	73	28	8-23	JIS 30K 80A
1	210	175	151	103	96	18	8-19	JIS 10K 100A
U	225	185	160	103	96	24	8-23	JIS 20K 100A
3	240	195	160	103	96	32	8-25	JIS 30K 100A
G	127	98.4	73	53	48	17.5	4-16	ANSI/JPI 150LB 1.5B
H	156	114.3	73	53	48	20.6	4-23	ANSI/JPI 300LB 1.5B
J	150	120.6	92	70	48	20	4-20	ANSI/JPI 150LB 2B
K	165	127	92	70	48	22.5	8-20	ANSI/JPI 300LB 2B
4	190	152.5	127	100	48	24	4-20	ANSI/JPI 150LB 3B
6	210	168	127	100	96	29	8-23	ANSI/JPI 300LB 3B
5	230	190.5	158	103	96	24	8-20	ANSI/JPI 150LB 4B
7	255	200	158	103	96	32	8-23	ANSI/JPI 300LB 4B

11th digit of the code symbols	L±1.5	MASS APPROX. (kg)	L1	L2	L3	NOTE3)		
						L4	L5	L6
Y	0	10.2 ~ 13.7						
A	50	10.7 ~ 17.7						
B	100	11.2 ~ 18.2	298	128	282	303	130	284
C	150	11.7 ~ 18.7						
D	200	12.2 ~ 19.2						

NOTE2) THE PRESSURE CONNECTOR IS LOCATED ON THE DOWN SIDE SURFACE OF THE DETECTOR, WHEN THE VENT/ DRAIN PLUG IS ATTACHED ON THE UPPER SIDE OF THE DETECTOR (WHEN THE 15TH DIGIT OF THE CODE SYMBOLS : C,E,D,P,Q,R).

NOTE3) WHEN THE 7TH DIGIT OF THE CODE SYMBOLS "H,M,T"

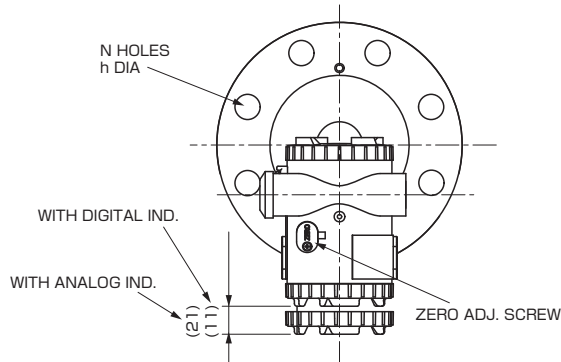

IN CASE OF 4TH DIGIT CODE "5, 7, 8, 9"

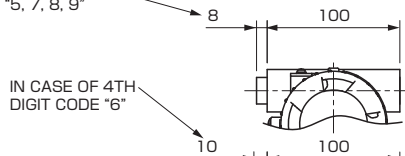

IN CASE OF 4TH DIGIT CODE "6"

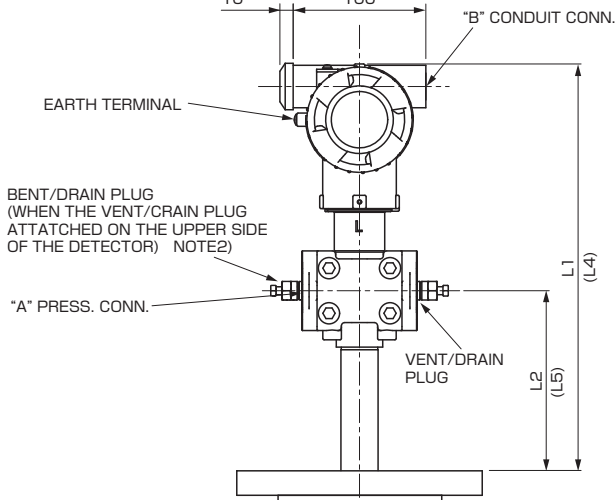

VENT/ DRAIN PLUG (WHEN THE VENT/ DRAIN PLUG ATTACHED ON THE UPPER SIDE OF THE DETECTOR) NOTE2)

"A" PRESS. CONN.

IN CASE OF FLANGE WITH 4 BOLT HOLES

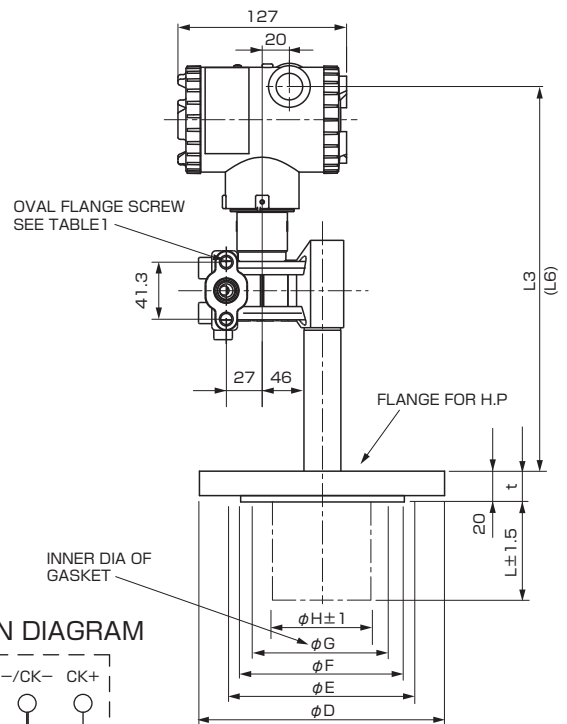

### CONNECTION DIAGRAM

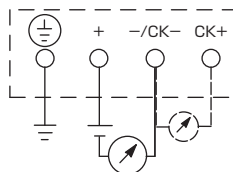

TABLE 2

Authorities	Intrinsic safety																					
ATEX	<p>Ex II 1 G                      Ex ia IIC T5 Tamb = -40°C to +50°C                      Ex ia IIC T4 Tamb = -40°C to +70°C</p> <p>Entity Parameters:                      Ui=28V, li=94.3mA, Pi=0.66W,                      Ci=26nF (Without Arrester), Li=0.6mH (Without analog indicator),                      Ci=36nF (With Arrester), Li=0.7mH (With analog indicator)</p>																					
Factory Mutual	<p>Class I II III                      Div.1 Groups A, B, C, D, E, F, G                      T4 Entity Type 4X</p> <table border="1"> <thead> <tr> <th colspan="2">Model code</th> <th>Tamb</th> </tr> <tr> <th>9th digit</th> <th>13th digit</th> <th></th> </tr> </thead> <tbody> <tr> <td>A,B,D</td> <td>Y,G,H,J</td> <td>-40°C to +85°C</td> </tr> <tr> <td>L,P,1,2</td> <td>Y,G,H,J</td> <td>-20°C to +80°C</td> </tr> <tr> <td>Q,S,4,5</td> <td>Y,G,H,J</td> <td>-20°C to +60°C</td> </tr> <tr> <td>E,F,H</td> <td>Y,G,H,J</td> <td>-40°C to +60°C</td> </tr> <tr> <td>-</td> <td>W,A,D</td> <td>-10°C to +60°C</td> </tr> </tbody> </table> <p>Entity Parameters:                      Vmax=28V, Imax=94.3mA, Pi=0.66W,                      Ci=35.98nF, Li=0.694mH</p>	Model code		Tamb	9th digit	13th digit		A,B,D	Y,G,H,J	-40°C to +85°C	L,P,1,2	Y,G,H,J	-20°C to +80°C	Q,S,4,5	Y,G,H,J	-20°C to +60°C	E,F,H	Y,G,H,J	-40°C to +60°C	-	W,A,D	-10°C to +60°C
Model code		Tamb																				
9th digit	13th digit																					
A,B,D	Y,G,H,J	-40°C to +85°C																				
L,P,1,2	Y,G,H,J	-20°C to +80°C																				
Q,S,4,5	Y,G,H,J	-20°C to +60°C																				
E,F,H	Y,G,H,J	-40°C to +60°C																				
-	W,A,D	-10°C to +60°C																				
CSA	<p>Class I                      Div.1 Groups A, B, C, D                      Class II                      Div.1 Groups E, F, G                      Class III                      Div.1</p> <p>Temp Code T5 Tamb max = +50°C                      Temp Code T4 Tamb max = +70°C</p> <p>Entity Parameters:                      Vmax=28V, Imax=94.3mA, Ci=25nF (Without Arrester),                      Ci=36nF (With Arrester), Li=0.6mH (Without analog meter),                      Li=0.7mH (With analog meter)</p>																					
TIIS	<p>Ex ia IIC T4                      Tamb max = +60°C</p> <p>Entity Parameters:                      Ui=28V, li=94.3mA, Pi=0.66W,                      Ci=40.92nF, Li=0.694mH</p>																					
IECEX Scheme	<p>Ex ia IIC T4                      Tamb = -40°C to +70°C                      Ex ia IIC T5                      Tamb = -40°C to +50°C</p> <p>Entity Parameters:                      Ui=28V, li=94.3mA, Pi=0.66W,                      Ci=26nF (Without Arrester), Li=0.6mH (Without analog indicator),                      Ci=36nF (With Arrester), Li=0.7mH (With analog indicator)</p>																					

Authorities	Flameproof																					
ATEX	<p>Ex II 2 GD                      Ex d IIC T6 IP66/67 T85°C                      Tamb = -40°C to +65°C                      Ex d IIC T5 IP66/67 T100°C                      Tamb = -40°C to +85°C</p>																					
Factory Mutual	<p>Class I                      Div.1 Groups B, C, D                      T6 Type 4X                      Class II III                      Div.1 Groups E, F, G                      T6 Type 4X                      Tamb max = +60°C</p>																					
CSA	<p>Class I                      Div.1 Groups C, D                      Class II                      Div.1 Groups E, F, G                      Class III                      Div.1</p> <p>Note) "Seal Not Required" enclosure is allowed.</p>																					
TIIS	<p>Ex do IIB+H<sub>2</sub> T4                      Tamb max = +60°C                      Maximum process temp. = +120°C</p>																					
IECEX Scheme	<p>Ex d IIC T5 IP66/67                      Tamb = -40°C to +85°C                      Ex d IIC T6 IP66/67                      Tamb = -40°C to +65°C</p>																					
Authorities	Type n Nonincendive																					
ATEX	<p>Ex II 3 GD                      EEx nL IIC T5 Tamb = -40°C to +50°C                      EEx nL IIC T4 Tamb = -40°C to +70°C</p> <p>Specific Parameters:                      Model without arrester:                      Ui=42.4V, li=113mA, Pi=1W,                      Ci=25.18nF, Li=0.694mH                      Model with arrester:                      Ui=32V, li=113mA, Pi=1W,                      Ci=35.98nF, Li=0.694mH</p> <p>EEx nAL IIC T5 Tamb = -40°C to +50°C                      EEx nAL IIC T4 Tamb = -40°C to +70°C</p> <p>Specific Parameters:                      Model without arrester:                      Umax=42.4V, Imax=113mA, Pmax=1W                      Model with arrester:                      Umax=32V, Imax=113mA, Pmax=1W</p>																					
Factory Mutual	<p>Class I II III                      Div.2 Groups A, B, C, D, F, G                      T4 Entity Type 4X</p> <table border="1"> <thead> <tr> <th colspan="2">Model code</th> <th>Tamb</th> </tr> <tr> <th>9th digit</th> <th>13th digit</th> <th></th> </tr> </thead> <tbody> <tr> <td>A,B,D</td> <td>Y,G,H,J</td> <td>-40°C to +85°C</td> </tr> <tr> <td>L,P,1,2</td> <td>Y,G,H,J</td> <td>-20°C to +80°C</td> </tr> <tr> <td>Q,S,4,5</td> <td>Y,G,H,J</td> <td>-20°C to +60°C</td> </tr> <tr> <td>E,F,H</td> <td>Y,G,H,J</td> <td>-40°C to +60°C</td> </tr> <tr> <td>-</td> <td>W,A,D</td> <td>-10°C to +60°C</td> </tr> </tbody> </table>	Model code		Tamb	9th digit	13th digit		A,B,D	Y,G,H,J	-40°C to +85°C	L,P,1,2	Y,G,H,J	-20°C to +80°C	Q,S,4,5	Y,G,H,J	-20°C to +60°C	E,F,H	Y,G,H,J	-40°C to +60°C	-	W,A,D	-10°C to +60°C
Model code		Tamb																				
9th digit	13th digit																					
A,B,D	Y,G,H,J	-40°C to +85°C																				
L,P,1,2	Y,G,H,J	-20°C to +80°C																				
Q,S,4,5	Y,G,H,J	-20°C to +60°C																				
E,F,H	Y,G,H,J	-40°C to +60°C																				
-	W,A,D	-10°C to +60°C																				



Information in this catalog is subject to change without notice.  
Read the instruction manuals thoroughly before using the products.

---

 **Fuji Electric Co., Ltd.**

[www.fujielectric.com](http://www.fujielectric.com)

**Instrumentation & Sensors Planning Dept.**

Gate City Ohsaki, East Tower, 11-2, Osaki 1-chome, Shinagawa-ku, Tokyo 141-0032, Japan

Phone: +81-3-5435-7021 Fax: +81-3-5435-7475

[www.fujielectric.com/products/instruments/](http://www.fujielectric.com/products/instruments/)